

All sound systems need a power panel - why not have ONE TOUCH AC power control?  
**Motorized circuit breakers sequence sound system AC power!**

MSP 341-xx Modular Sequencing Panelboard - The Electrician's choice



**LynTec** Modular Sequencing series panels add branch circuit sequencing to the main and branch circuit breaker functions normally found in a Load Center or Panelboard.

**How they work**  
 Applies AC to low level, front-end electronics... waits for them to stabilize... (clicks and pops are ignored by un-powered power amplifiers)...  
 AC is then sequenced to power amplifiers to spread high inrush currents over time.  
 Protects valuable loudspeaker systems by delaying turn-on until all low level equipment has stabilized.

**ONE TOUCH**  
 REMOTE POWER CONTROL

SHOWN ACTUAL SIZE



Green LED illuminated Red

**SS-2 Sequencer Switch Set**

One SS-2 switch set is supplied with each panel.

**LynTec**  
 Modular Sequencing series Power Panels

**BENEFITS**

- ✓ **ONE TOUCH remote power control**
  - Immediate visual feedback provided by flashing **ON** switch.
  - Light stays **ON** to verify sequence completion.
  - Process is reversed for turn-off sequence.
  - May be controlled from one to six locations.
  - Multiple sequencing panels may be daisy-chained for larger systems.
- ✓ **Reduced installation labor**
  - One wall-mounted, sequenced power panel feeds AC power to all rack and console receptacles.
- ✓ **Low power consumption**
  - **BMB** (Bolt-on) and **MB** (Clip-on) series motorized circuit breakers require no holding current (like DC relays) or heat sinks (like solid state relays).
  - Runs cool — lasts long.
- ✓ **Automatic load shedding and *BROWNOUT* protection**
  - A voltage sensing system automatically sheds the load when AC mains voltage drops below 95 volts for 2 seconds.
  - Capacitor-stored energy zips-off all circuits 2 seconds after power fails.
  - The system automatically re-sequences without operator intervention when stable voltage (above 105 volts for 5 seconds) resumes.
  - Reduces the start-up load for auxiliary power units.
  - Smart wake-up is ideal for unattended systems.
- ✓ **Kill**
  - Emergency instant shutdown may be triggered by an external contact closure.
  - System automatically re-sequences when contact opens.
- ✓ **HurryOff — *Ohh..... no..... switch* – Kill without restart**
  - By holding **any** OFF switch down for 2 seconds, the operator can trigger an instant shutdown with no automatic restart.

# Planning and Layout Worksheet — As-built door label

## MSP 341-xx Sound System Sequencing Panel

Breaker types, sizes, positions and connections

Job \_\_\_\_\_

Panel \_\_\_\_\_

Comments \_\_\_\_\_

by \_\_\_\_\_ Date \_\_\_\_\_

Transfer as-built information to the door label upon completion.

Keep this sheet for as-built documentation

Available as PDF download  
[www.lyntec.com/139-0246\\_MSP341PInr.pdf](http://www.lyntec.com/139-0246_MSP341PInr.pdf)

Low voltage control  
 Wiring Diagram  
 located inside  
 left cover.

[www.lyntec.com/139-0327\\_SequencerLV\\_Wiring.pdf](http://www.lyntec.com/139-0327_SequencerLV_Wiring.pdf)

**LynTec**  
**MSP 341-xx** (65k AIR main)  
 Modular Sequencing Panelboard

Cabinet outline  
 Surface mount only  
 Outside dimensions  
 36" w., 50" h., 6.13" d.

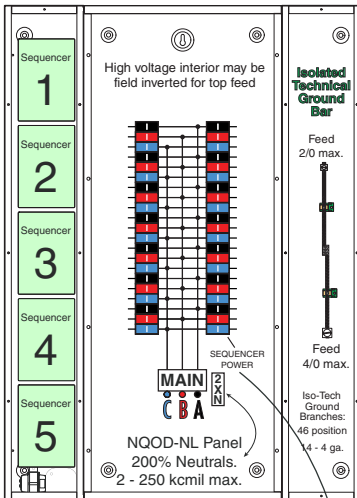

Square D NQOD-NL MB Panel with LynTec sidecars.  
 Standard MSP Main Breaker: **225 Amp.** - 65k AIR - JGP36225  
 Main Breaker options — Part# suffix  
**Bold** = Amps  
 -MHG3**125**,  
 -MJG**150**, -MJG3**175** or -MJG3**200**  
 Square D #s  
 HGP36**125** (65k AIR)  
 JGP36**150** (65k AIR)  
 JGP36**175** (65k AIR)  
 JGP36**200** (65k AIR)  
 [Amps Interrupt Rating]

Main Breaker wire:  
 #4-350 kcmil Al or 250 kcmil Cu.  
 200%, Non-Linear, Neutral has one feed lug that accepts two 250 kcmil Cu wires.

Feed thru lugs **NOT** available on 200% NL panel.

Each motorized breaker is controlled by a sequencer.  
 As-built door label example:  
 Step # **1a** (1a) (# in parenthesis is suggested breaker connection in sequencer).  
 Bold line around box  is the suggested sequencer board: #1(Top), #2, #3, or #4.  
 Fill in  box to indicate which sequencer board this breaker is connected to.

1	Phase A	2
Amp. <input type="checkbox"/> Un-motorized. <input type="checkbox"/> Motorized-Step # _____ (1a)		Amp. <input type="checkbox"/> Un-motorized. <input type="checkbox"/> Motorized-Step # _____ (1b)
3	Phase B	4
Amp. <input type="checkbox"/> Un-motorized. <input type="checkbox"/> Motorized-Step # _____ (2a)		Amp. <input type="checkbox"/> Un-motorized. <input type="checkbox"/> Motorized-Step # _____ (2b)
5	Phase C	6
Amp. <input type="checkbox"/> Un-motorized. <input type="checkbox"/> Motorized-Step # _____ (3a)		Amp. <input type="checkbox"/> Un-motorized. <input type="checkbox"/> Motorized-Step # _____ (3b)
7	A	8
Amp. <input type="checkbox"/> Un-motorized. <input type="checkbox"/> Motorized-Step # _____ (4a)		Amp. <input type="checkbox"/> Un-motorized. <input type="checkbox"/> Motorized-Step # _____ (4b)
9	B	10
Amp. <input type="checkbox"/> Un-motorized. <input type="checkbox"/> Motorized-Step # _____ (5a)		Amp. <input type="checkbox"/> Un-motorized. <input type="checkbox"/> Motorized-Step # _____ (5b)
11	C	12
Amp. <input type="checkbox"/> Un-motorized. <input type="checkbox"/> Motorized-Step # _____ (6a)		Amp. <input type="checkbox"/> Un-motorized. <input type="checkbox"/> Motorized-Step # _____ (6b)
13	A	14
Amp. <input type="checkbox"/> Un-motorized. <input type="checkbox"/> Motorized-Step # _____ (1a)		Amp. <input type="checkbox"/> Un-motorized. <input type="checkbox"/> Motorized-Step # _____ (1b)
15	B	16
Amp. <input type="checkbox"/> Un-motorized. <input type="checkbox"/> Motorized-Step # _____ (2a)		Amp. <input type="checkbox"/> Un-motorized. <input type="checkbox"/> Motorized-Step # _____ (2b)
17	C	18
Amp. <input type="checkbox"/> Un-motorized. <input type="checkbox"/> Motorized-Step # _____ (3a)		Amp. <input type="checkbox"/> Un-motorized. <input type="checkbox"/> Motorized-Step # _____ (3b)
19	A	20
Amp. <input type="checkbox"/> Un-motorized. <input type="checkbox"/> Motorized-Step # _____ (4a)		Amp. <input type="checkbox"/> Un-motorized. <input type="checkbox"/> Motorized-Step # _____ (4b)
21	B	22
Amp. <input type="checkbox"/> Un-motorized. <input type="checkbox"/> Motorized-Step # _____ (5a)		Amp. <input type="checkbox"/> Un-motorized. <input type="checkbox"/> Motorized-Step # _____ (5b)
23	C	24
Amp. <input type="checkbox"/> Un-motorized. <input type="checkbox"/> Motorized-Step # _____ (6a)		Amp. <input type="checkbox"/> Un-motorized. <input type="checkbox"/> Motorized-Step # _____ (6b)
25	A	26
Amp. <input type="checkbox"/> Un-motorized. <input type="checkbox"/> Motorized-Step # _____ (1a)		Amp. <input type="checkbox"/> Un-motorized. <input type="checkbox"/> Motorized-Step # _____ (1b)
27	B	28
Amp. <input type="checkbox"/> Un-motorized. <input type="checkbox"/> Motorized-Step # _____ (2a)		Amp. <input type="checkbox"/> Un-motorized. <input type="checkbox"/> Motorized-Step # _____ (2b)
29	C	30
Amp. <input type="checkbox"/> Un-motorized. <input type="checkbox"/> Motorized-Step # _____ (3a)		Amp. <input type="checkbox"/> Un-motorized. <input type="checkbox"/> Motorized-Step # _____ (3b)
31	A	32
Amp. <input type="checkbox"/> Un-motorized. <input type="checkbox"/> Motorized-Step # _____ (4a)		Amp. <input type="checkbox"/> Un-motorized. <input type="checkbox"/> Motorized-Step # _____ (4b)
33	B	34
Amp. <input type="checkbox"/> Un-motorized. <input type="checkbox"/> Motorized-Step # _____ (5a)		Amp. <input type="checkbox"/> Un-motorized. <input type="checkbox"/> Motorized-Step # _____ (5b)
35	C	36
Amp. <input type="checkbox"/> Un-motorized. <input type="checkbox"/> Motorized-Step # _____ (6a)		Amp. <input type="checkbox"/> Un-motorized. <input type="checkbox"/> Motorized-Step # _____ (6b)
37	A	38
Amp. <input type="checkbox"/> Un-motorized. <input type="checkbox"/> Motorized-Step # _____ (1a)		Amp. <input type="checkbox"/> Un-motorized. <input type="checkbox"/> Motorized-Step # _____ (1b)
39	B	40
Amp. <input type="checkbox"/> Un-motorized. <input type="checkbox"/> Motorized-Step # _____ (2a)		Amp. <input type="checkbox"/> Un-motorized. <input type="checkbox"/> Motorized-Step # _____ (2b)
41	C	
Amp. <input type="checkbox"/> Un-motorized. <input type="checkbox"/> Motorized-Step # _____ (3a)		

**SEQUENCER POWER**  
 10A un-motorized breaker supplied installed.

MS-12 Sequencer circuit boards in left-hand, low voltage cabinet.

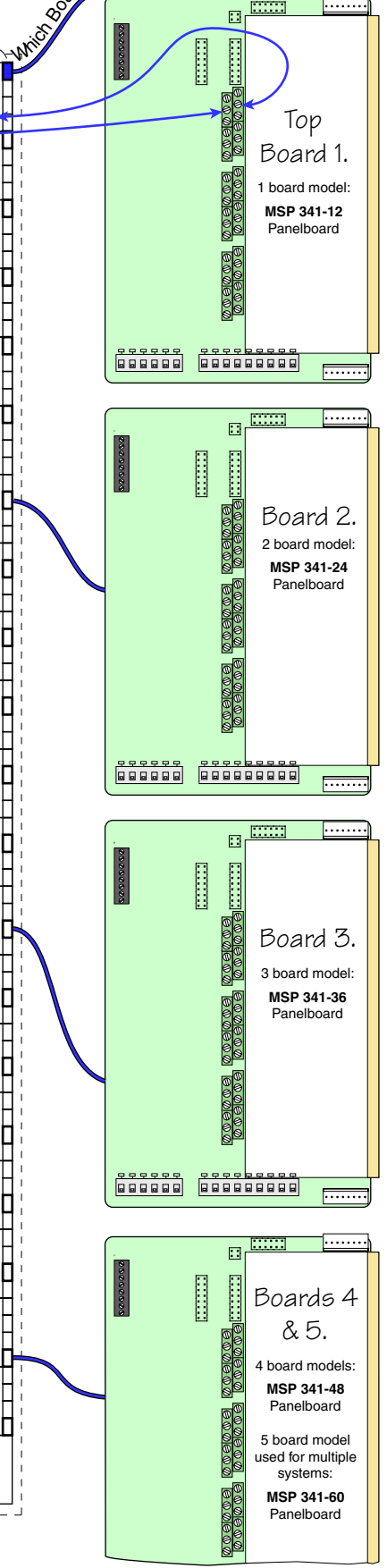

# Outline Drawing

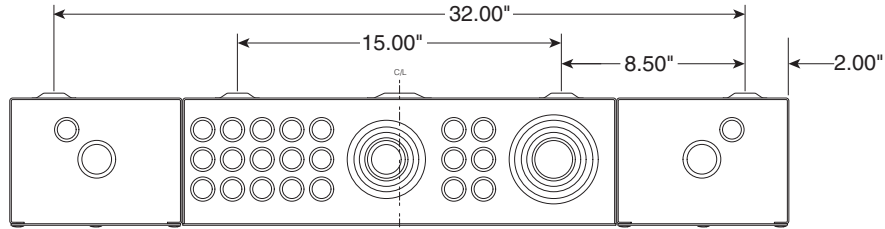

**LynTec**  
**MSP 341-xx** (65k AIR main)  
 Modular Sequencing Panelboard

Square D NQOD-NL MB Panel  
 with LynTec sidecars.

Standard **MSP** Main Breaker:  
**225** Amp. - 65k AIR - MJG32225

Main Breaker options — Part# suffix  
**Bold** = Amps  
 -MHG3110, -MHG3125,  
 -MJG3150, -MJG3175 or -MJG3200  
 (all 65k AIR)  
 [Amps Interrupt Rating]

Main Breaker wire:  
 #4-350 kcmil Al or 250 kcmil Cu.  
 200% Neutral has one feed lug that  
 accepts two 250 kcmil Cu wires.

Outside dimensions  
 36" w., 50" h., 6.13" d.

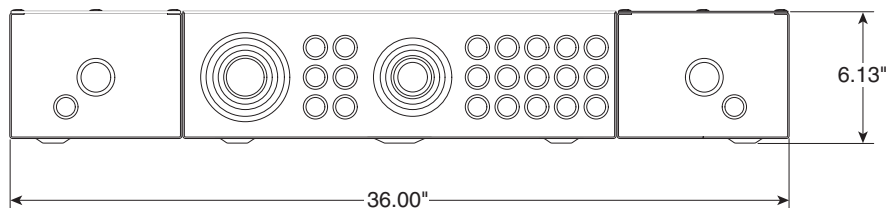
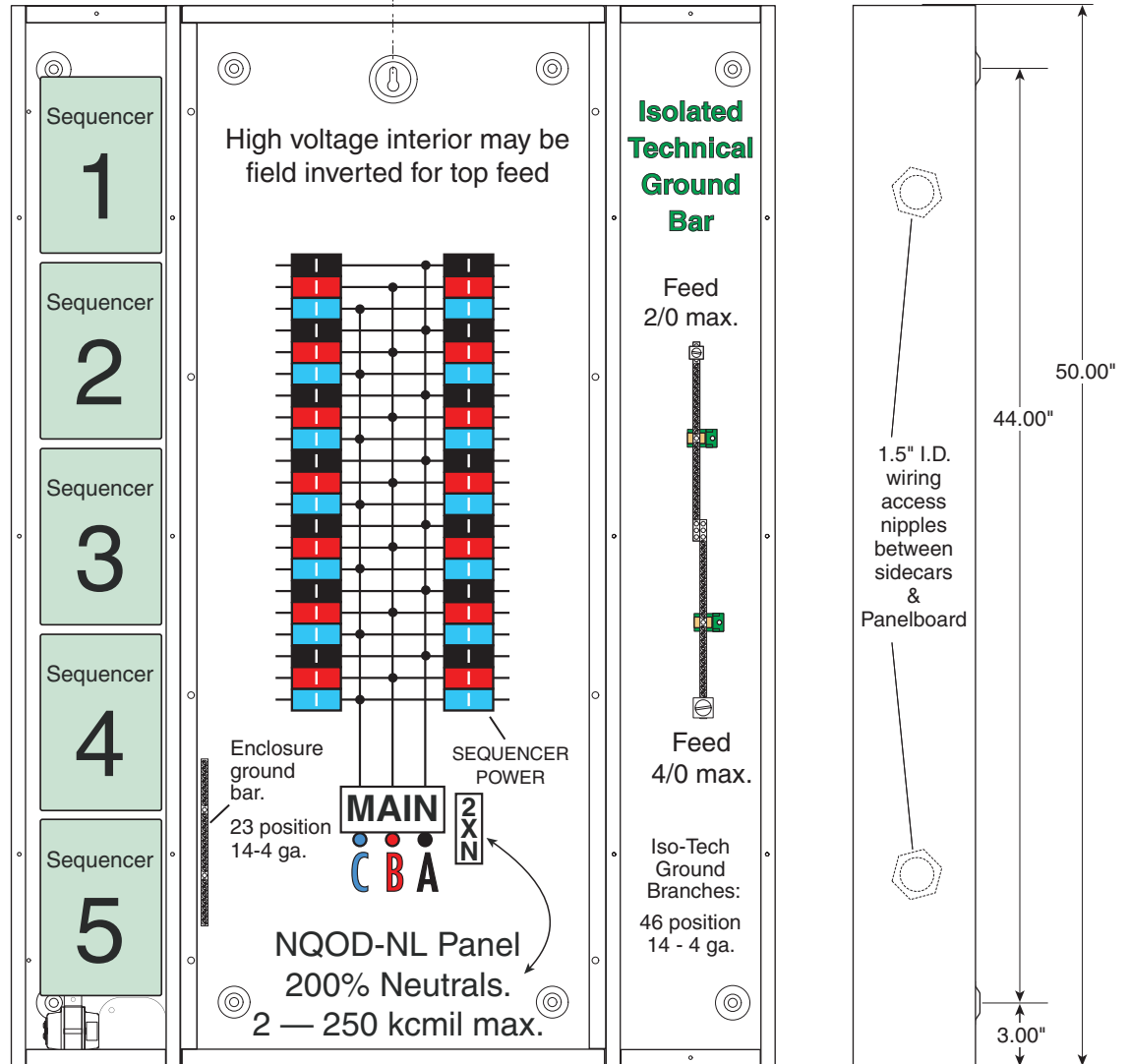



## Selection Information

H- and J- frame Thermal-magnetic Molded Case  
150 and 250 Ampere Frame — Class 611

150 A H-frame	250 A J-frame
 <p><b>LynTec</b> LCP341-xx MSP 341-xx</p> <p>Main breaker suffix -MHG3110 = 110 A -MHG3125 = 125 A</p> <p>Special Order Option NCNR Non Cancellable</p>	 <p><b>LynTec</b> LCP 341-xx MSP 341-xx</p> <p>The standard main breaker is a JGP36225 and requires no suffix number.</p> <p>Main breaker suffix options -MJG3150 = 150 A -MJG3175 = 175 A -MJG3200 = 200 A -MJG3225 = 225 A</p>

Circuit Breaker Type	HD	HG	HJ	HL	JD	JG	JJ	JL
Number of Poles	2,3	2,3	2,3■	2,3■	2,3■	2,3■	2,3■	2,3■
Current Range	15–150 A	15–150 A	15–150 A	15–150 A	150–250 A	150–250 A	150–250 A	150–250 A

Interrupting Ratings									
	240 V	25	65	100	125	25	65	100	125
UL/CSA/NOM 50/60 Hz	480Y/277 Vac	18	35	65	100	18	35	65	100
	480 Vac	18	35	65	100	18	35	65	100
	600Y/347 Vac	14	18	25	50	14	18	25	50
	600 Vac	14	18	25	50	14	18	25	50
DC Ratings	125/250 Vdc	20	20	20	20	20	20	20	20
	500 Vdc	TBD	TBD	TBD	TBD	TBD	TBD	TBD	TBD
IEC 947-2 Icu/Ics	220/240 Vac	25/25	65/65	100/100	125/125	25/25	65/65	100/100	125/125
	380/415 Vac	18/18	35/35	65/65	100/100	18/18	35/35	65/65	100/100
	500/525 Vac	14/14	18/18	25/25	50/50	14/14	18/18	25/25	50/50

Special Ratings									
Fed. Specs W-C-375B/GEN	✓	✓	✓	✓	✓	✓	✓	✓	✓
HACR (2, 3-pole)	✓	✓	✓	✓	✓	✓	✓	✓	✓

Connections/Terminations									
Unit Mount	✓	✓	✓	✓	✓	✓	✓	✓	✓
I-Line®	✓	✓	✓	✓	✓	✓	✓	✓	✓
Rear Connection	✓▲	✓▲	✓	✓	✓	✓	✓	✓	✓
Drawout	✓▲	✓▲	✓	✓	✓	✓	✓	✓	✓
Optional Lugs	✓▲	✓▲	✓	✓	✓	✓	✓	✓	✓
Unit Mount	✓	✓	✓	✓	✓	✓	✓	✓	✓

Accessories and Modifications									
Shunt Trip	✓	✓	✓	✓	✓	✓	✓	✓	✓
Undervoltage Trip	✓	✓	✓	✓	✓	✓	✓	✓	✓
Auxiliary Switches	✓	✓	✓	✓	✓	✓	✓	✓	✓
Alarm Switch	✓	✓	✓	✓	✓	✓	✓	✓	✓
Motor Operator	✓▲	✓▲	✓	✓	✓	✓	✓	✓	✓
Handle Operators	✓▲	✓▲	✓	✓	✓	✓	✓	✓	✓
Handle Padlock Attachment	✓▲	✓▲	✓	✓	✓	✓	✓	✓	✓
Handle Mechanical Interlocks	✓▲	✓▲	✓	✓	✓	✓	✓	✓	✓
Optional GF Protection	...	...	...	...	...	...	...	...	...

Trip System Type									
Thermal-magnetic	✓	✓	✓	✓	✓	✓	✓	✓	✓
Instantaneous-only (MCP)	...	...	...	...	...	...	...	...	...
Molded Case Switch (Automatic)	✓	✓	✓	✓	✓	✓	✓	✓	✓
Electronic	...	...	...	...	...	...	...	...	...

Dimensions									
Dimensions (3P Unit Mount)	Height IN (mm)	6.4 (163)				7.5 (191)			
	Width IN (mm)	4.1 (104)				4.1 (104)			
	Depth IN (mm)	3.4 (86)				3.4 (86)			

▲ Not available in HD and HG two-pole rating (2-pole module)  
■ 2-pole in a 3-pole module.  
12/01/05

For **Branch Breaker Series Ratings**  
see [http://www.lyntec.com/139-0407\\_Series\\_Ratings.pdf](http://www.lyntec.com/139-0407_Series_Ratings.pdf)

# Series Ratings

For NQOD and NF Panelboards  
Class 1630, 1670

This page contains UL Tested and Certified series combination ratings for panelboards. These ratings apply to either an integral main located in the same enclosure or a remote main located in a separate enclosure.

## NQOD Series Ratings

Maximum System Voltage AC <sup>c</sup>	Maximum Short Circuit Current Rating (RMS Symmetrical)	Integral or Remote Main Circuit Breakers and Remote Main Fuses	Branch Circuit Breaker Designations and Allowable Ampere Ranges <sup>ab</sup>			
			Type	1-pole	2-pole	3-pole
120/240 1Ø	22k	MG	QO (B)	15-30 A	...	...
	42k	HD, JD	QO (B) PL	15-30 A	15-60 A	15-30 A
	65k	HG, JG	QO (B) PL	15-30 A	15-60 A	15-30 A
	100k	HJ, JJ	QO (B) PL	15-30 A	15-60 A	15-30 A
	125k	HL, JL	QO (B) PL	15-30 A	15-60 A	15-30 A
120/240 1Ø 208Y/120	100k	DJ 400 A	QO (B)	15-70 A	15-125 A	...
			QO (B) GFI	15-30 A	40-60 A	...
	100k	QJ	QO (B) VH	...	150 A	15-150 A
			QO (B) PL	15-30 A	...	...
			QO (B) AF1	15-20 A	...	...
			QO (B)	15-70 A	15-125 A	15-30 A
			QO (B) AS	15-30 A	15-30 A	15-30 A
			QO (B) GFI	15-30 A	15-60 A	...
			QO (B) PL	15-30 A	15-60 A	15-30 A
			QO (B) VH	...	150 A	35-150 A
QO (B) AF1	15-20 A	...	...			
208Y/120	18k	LA/LH (L) 34200MC LA/LH (L) 34225MC LA/LH (L) 34250MC LA/LH (L) 34400MC	QO (B)	15-30 A	15-30 A	15-30 A
LynTec models LCLC 326 MSLC 326 MSP 338 MSP 139	22k	UMB-xx QO (B) VH MB-xx	QO (B)	15-70 A	15-125 A	15-100 A
			QO (B) AS	15-30 A	15-30 A	15-30 A
	22k	Q2-Hf	QO (B) GFI	15-30 A	15-60 A	...
			QO (B) PL	15-30 A	15-30 A	...
			QO (B) AF1	15-20 A	...	...
			QO (B)	15-70 A	15-100 A	15-30 A
			QO (B) GFI	15-30 A	15-30 A	...
			QO (B) PL	15-30 A	15-30 A	...
			QO (B) VH	...	150 A	...
			QO (B) AF1	15-20 A	...	...
25k	QD	UMB-xx MB-xx	QO (B)	15-70 A	15-125 A	15-30 A
		QO (B) AS	15-30 A	15-30 A	15-30 A	
25k	ED, Fdf	QO (B)	15-70 A	15-125 A	15-100 A	
		QO (B) GFI	15-30 A	15-60 A	...	
25k	Kdf	QO (B)	15-70 A	15-125 A	15-100 A	
		QO (B) AS	15-30 A	15-30 A	15-30 A	
25k	HD, JD	QO (B)	15-70 A	15-125 A	15-100 A	
		QO (B) VH	...	150 A	35-150 A	
42k	LA, MA	Q2L-Hf	...	110-225 A	110-225 A	
		QDL	...	70-225 A	70-225 A	
42k	MG	QO (B) VH	15-30 A	15-30 A	15-30 A	
		QO (B) PL	15-30 A	15-60 A	15-30 A	
42k	LC 600 A Maximum	QO (B)	15-70 Ad	...	...	
		QO (B) VH	15-30 A	15-125 A	15-100 A (3P 208 V Max.)	
65k	600 A Maximum	QO (B) GFI	15-30 Ae	15-60 A	...	
		QO (B) AF1	15-20 A	...	...	
65k	DJ 400 A	QO (B)	15-70 A	15-125 A	15-100 A	
		QO (B) VH	...	150 A	15-150 A	
65k	EG, Fgf, KGf	QO (B)	15-70 A	15-125 A	15-100 A	
		QO (B) GFI	15-30 A	15-60 A	...	
65k	QG	QO (B)	15-70 A	15-125 A	15-30 A	
		QO (B) AS	15-30 A	15-30 A	15-30 A	
65k	QG, HG, JG	QO (B) VH	...	...	35-150 A	
		QO (B) GFI	15-30 A	15-60 A	...	
65k	HG, JG	UMB-xx BUMB-xx	QO (B)	15-70 A	15-125 A	15-100 A
		QO (B) VH	...	150 A	35-150 A	
65k	FCL22 KCL22 FCL32 KCL32	QO (B)	15-70 A	15-100 A	15-100 A	
		QO (B) AS	15-30 A	15-30 A	15-30 A	
65k	400 A Max. Class J or T6 Fuses	QO (B) GFI	15-30 A	15-60 A	...	
		QO (B) PL	15-30 A	15-60 A	15-30 A	
100k	FCL24 KCL24 FCL34 KCL34	QO (B)	15-70 A	15-100 A	15-100 A	
		QO (B) AS	15-30 A	15-30 A	15-30 A	
100k	200 A Max. Class T3 Fuses	QO (B) PL	15-30 A	15-30 A	...	
		QO (B) AF1	15-20 A	...	...	
100k	EJ, FJf	QO (B)	15-70 A	15-125 A	15-100 A	
		QO (B) GFI	15-30 A	15-60 A	...	
100k		QO (B)	15-70 A	15-125 A	15-100 A	
		QO (B) AF1	15-20 A	...	...	

LynTec models  
LCLC 326  
MSLC 326  
MSP 338  
MSP 139

LynTec models  
LCLC 341  
MSLC 341

LynTec models  
MSLC 113  
MSLC 127  
MSLC 129  
are series rated 22k AIR.  
see QO130Mxx on pg 1-3 of Digest

8 PANELBOARDS

LynTec models  
MSLCH 341  
MSP 119  
MSP 141

LCP 341  
MSP 341

**QOxxx (B) = BUMB series Bolt-on, UnMotorized Breaker**  
-xxx = poles. xxx = trip current.  
[1 pole] BUMB-15, BUMB-20, BUMB-30  
[2 pole] BUMB-215, BUMB-220, BUMB-230  
[3 pole] BUMB-315, BUMB-320, BUMB-330

**QOxxx = UMB series clip-on, UnMotorized Breaker**  
-xxx = poles. xxx = trip current.  
[1 pole] UMB-15, UMB-20, UMB-30  
[2 pole] UMB-215, UMB-220, UMB-230  
[3 pole] UMB-315, UMB-320, UMB-330  
All 15 & 20 A breakers are HM (High Magnetic)

## NQOD Series Ratings (Continued)

Maximum System Voltage AC <sup>c</sup>	Maximum Short Circuit Current Rating (RMS Symmetrical)	Integral or Remote Main Circuit Breakers and Remote Main Fuses	Branch Circuit Breaker Designations and Allowable Ampere Ranges <sup>ab</sup>			
			Type	1-pole	2-pole	3-pole
240	100k	HJ, JJ	QO (B)	15-70 A	15-125 A	15-100 A
			QO (B) VH	...	...	35-150 A
	125k	HL, JL	QO (B) GFI	15-30 A	15-60 A	...
			QO (B) PL	15-30 A	15-60 A	15-30 A
200k	FI, KI	QO (B) AF1	15-20 A	...	...	
		QO (B) H	...	150 A	...	
200k	Maximum Fuses 200 A Class J or T6 400 A Class T3	QO (B)	15-70 A	15-125 A	15-100 A	
		QO (B) AS	15-30 A	15-30 A	15-30 A	
200k		QO (B) GFI	15-30 A	15-60 A	...	
		QO (B) AF1	15-20 A	...	...	

▲ Suffixes HID, SWD and SWN may also be applied to the applicable branch circuit breakers shown above, except suffix SWN may NOT be applied in combination with LC main circuit breakers.

■ Where QO (B) circuit breakers are shown above, QO (B) H, QO (B) VH, and QH (B) circuit breakers may also be used.

◆ For shown circuit breakers rated less than this maximum voltage, the indicated short circuit current rating also applies, but at the voltage rating of the circuit breaker.

★ Only 15-30 A circuit breakers may be used when the LC circuit breaker is rated 450, 500 or 600 A.

▼ Circuit breakers may not be used when the LC circuit breaker is rated 450, 500 or 600 A.

△ Obsolete. Contact your nearest Square D/Schneider Electric sales office for replacement circuit breaker. One-pole FJ circuit breakers are still available.

Where QO(B) GFI circuit breakers are shown above, QO(B), EPD circuit breakers may also be used.

## NF Series Ratings

Maximum System Voltage AC	Maximum Short Circuit Current Rating (RMS Symmetrical)	Main Type	Branch Type	Poles
240	65,000	EG, FH, FGF, KH, LH, MH, MX, HG, JG	EDB, EDB-EPD	1, 2 & 3
		EG	ECB-G3	
	100,000	EJ, FC, FJf, KC, LC, LX, HJ, JJ	EDB, EDB-EPD, EGB	
		EJ, FC, KC, HJ, JJ	ECB-G3	
	125,000	HL, JL	EDB, EDB-EPD, EGB, ECB-G3	
		FI, KI, LI, LXI	ECB-G3	
480Y/277	35,000	EG, FGF, KH, LH, HG, JG	EDB, EDB-EPD	1, 2 & 3
		EG, HG, JG	ECB-G3	
	65,000	EJ, FC, FJf, KC, LC, LX, HJ, JJ	EDB, EDB-EPD, EGB	
		EJ, FC, KC, HJ, JJ	ECB-G3	
	100,000	HL, JL	EDB, EDB-EPD, EGB	
		FI, KI, LI, LXI	ECB-G3	
600Y/347	18,000	HG, JG, MG	EDB, EDB-EPD	1, 2, 3
		EJ, FI, KH, KL, LC, LE, LX, LI, LXI, HJ, JJ	EDB, EDB-EPD, EGB	
	25,000	LH	EDB(15-70 A), EGB	
		LC, LE	EDB, EDB-EPD, EGB, EJB	
	35,000	HL, JL	EDB, EDB-EPD, EGB	
		FI, KI	ECB-G3	
65,000	LI, XI	EJB		
	Remote Main Fuse			
240	200,000	200 Ampere Maximum Class J or T (600V)	ECB-G3	1, 2 & 3
	100,000	400 Ampere Maximum Class J or T (600V)	EDB, EDB-EPD, EGB, EJB	
480Y/277	200,000	200 Ampere Maximum Class J or T (600V)	EDB, EDB-EPD, EGB, EJB	1, 2 & 3
	200,000	200 Ampere Maximum Class J or T (600V)	ECB-G3	
600Y/347	200,000	200 Ampere Maximum Class J or T (600V)	EDB, EDB-EPD, EGB, EJB	1, 2 & 3
	200,000	200 Ampere Maximum Class J or T (600V)	ECB-G3	

**QOPLxxx-5393 = BMB series Bolt-on, Motorized. (REMOTELY OPERATED)**  
-xxx = poles. xxx = trip current. -5393 suffix denotes special 60" control wires.  
[1 pole] BMB-15, BMB-20, BMB-30  
[2 pole] BMB-215, BMB-220, BMB-230, BMB-240, BMB-250, BMB-260  
[3 pole] BMB-315, BMB-320, BMB-330

**QOPLxxx-5393 = MB series clip-on, Motorized. (REMOTELY OPERATED)**  
-xxx = poles. xxx = trip current. -5393 suffix denotes special 60" control wires.  
[1 pole] MB-15, MB-20, MB-30  
[2 pole] MB-215, MB-220, MB-230, MB-240, MB-250, MB-260  
[3 pole] MB-315, MB-320, MB-330

# Instruction Bulletin

## QO-PL (Plug-on), QOB-PL (Bolt-on) Powerlink<sup>®</sup> Remotely Operated Circuit Breakers

(Use in Type QO Load Centers and Type NQO, NQOB, and NQOD Panelboards)

Retain for future use.

### REQUIREMENTS

#### Remotely Operated Circuit Requirements

#### **⚠ DANGER**

##### HAZARD OF ELECTRIC SHOCK, BURN, OR EXPLOSION.

When servicing a branch circuit fed by a remotely operated circuit breaker, move handle of remotely operated circuit breaker to OFF position. Do not rely on remote operation to open circuit breaker.

**Failure to follow these instructions will result in personal injury or death.**

### CIRCUIT BREAKER INSTALLATION

#### **⚠ DANGER**

##### HAZARD OF ELECTRIC SHOCK, EXPLOSION, OR ARC FLASH

- Apply appropriate personal protective equipment (PPE) and follow safe electrical work practices. See NFPA 70E.
- This equipment must be installed and serviced only by qualified electrical personnel.
- Turn off all power supplying this equipment before working on or inside equipment.
- Always use a properly rated voltage sensing device to confirm power is off.
- Replace all devices, doors, and covers before turning on power to this equipment.

**Failure to follow these instructions will result in death, or serious injury.**

See page 2 for  
**LynTec**  
part number explanation

POWERLINK<sup>®</sup> QO(B)-PL Remotely Operated Circuit Breakers require a power supply capable of delivering at least two amperes at 24 Vdc for a minimum of 50 milliseconds. One-, two-, and three-pole circuit breakers all have one internal motor, and power requirements are the same regardless of the number of poles and ampere ratings.

The required power supply ampacity and control device contact rating are determined by the number of circuit breakers to be switched simultaneously (i.e., four circuit breakers switched simultaneously require a power supply and a control device contact rated 8 amperes minimum). The control device may be either a normally-open (NO)/normally-closed (NC) contact; a single-pole, double-throw switch (SPDT); or other three-wire control device.

1. Turn off all power supplying this equipment before working on or inside equipment.
2. Before installing circuit breaker turn circuit breaker handle to OFF position.
3. Remove panelboard cover and deadfront. Verify power is off with voltage meter before proceeding.

**Installation of circuit breaker into panelboard/load center (refer to figure below)**

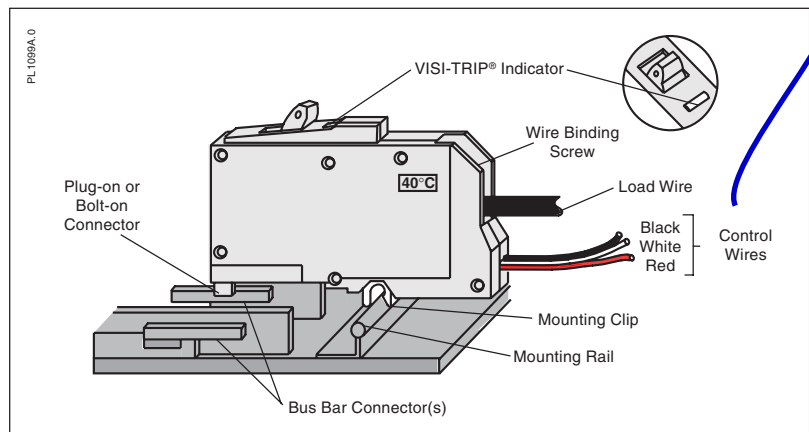

4. Except for remotely operated connections, QO(B)-PL remotely operated circuit breakers are installed in a panelboard/load center the same as conventional QO(B) circuit breakers.

**Connection of remotely operated circuit (refer to the figure on next page)**

5. Assure that power supply and control device meet requirements listed under "Remotely Operated Circuit Requirements."

**All LynTec supplied breakers have special 60" control wires. (Square D standards are 18".)**

**CIRCUIT BREAKER INSTALLATION**

**CAUTION**

**HAZARD OF CIRCUIT BREAKER DAMAGE.**

Connect the 24 Vdc remote control wiring as shown on this page.

**Failure to follow these instructions can permanently damage the remotely operated circuit breaker.**

**LynTec**  
 part numbers

**MB series motorized circuit breakers (Snap-On)**  
 May be used in LCLC, LCP, MSLC, MSP, SLC or SP series panels.

**BMB series motorized circuit breakers (Bolt-On)**  
 Use only in LCP, MSP or SP Panelboards

All **BMB** & **MB** series breakers have Square D part number suffix of -5393 indicating a special 60 inch lead length for remote control wires required to connect to LynTec control boards in low voltage cabinet.

\*\* = Stocked items

\*\***MB-15** = 15 Amp. Square D QO-115PL-5393

\*\***BMB-15** = 15 Amp. Square D QOB-115PL-5393

\*\***MB-20** = 20 Amp. Square D QO-120PL-5393

\*\***BMB-20** = 20 Amp. Square D QOB-120PL-5393

\*\***MB-30** = 30 Amp. Square D QO-130PL-5393

\*\***BMB-30** = 30 Amp. Square D QOB-130PL-5393

Two pole motorized - call for pricing & delivery

**MB-215** = 15 Amp. Square D QO-215PL-5393

**BMB-215** = 15 Amp. Square D QOB-215PL-5393

\*\***MB-220** = 20 Amp. Square D QO-220PL-5393

\*\***BMB-220** = 20 Amp. Square D QOB-220PL-5393

**MB-230** = 30 Amp. Square D QO-230PL-5393

**BMB-230** = 30 Amp. Square D QOB-230PL-5393

40A, 50A or 60A, Two pole also available on Special Order

Three pole motorized - call for pricing & delivery

**MB-315** = 15 Amp. Square D QO-315PL-5393

**BMB-315** = 15 Amp. Square D QOB-315PL-5393

**MB-320** = 20 Amp. Square D QO-320PL-5393

**BMB-320** = 20 Amp. Square D QOB-320PL-5393

**MB-330** = 30 Amp. Square D QO-330PL-5393

**BMB-330** = 30 Amp. Square D QOB-330PL-5393

LynTec also stocks **UMB** & **BUMB** (un-motorized) QO series circuit breakers including HM (High Magnetic). Recommended for eliminating nuisance trips in high inrush applications. [All BMB & MB-x15's and BMB & MB-x20's are HM breakers.]

**800-724-4047**

LynTec ■ www.LynTec.com

8401 Melrose Dr., Lenexa, KS 66214, USA

Voice 913-529-2233 • Fax 888-722-4157 or 913-529-4157

LynTec overprint 139-0216-08.2 9/23/06

Square D Company  
 3700 Sixth Street SW  
 Cedar Rapids IA 52404 USA  
 1-888-SquareD (1-888-778-2733)  
 www.SquareD.com

- All wiring and splicing must comply with applicable code requirements for Class 1 circuits. Refer to paragraph 373-8 and article 725 of the National Electrical Code.
- Three #18 AWG control wires are attached to the remotely operated circuit breaker for connection to the power supply and remote control device and should be cut to the required length to reach the splice connections. Use #18 AWG or larger conductors with 600 V insulation and approved wire connectors for splices.
- Connect the black lead of the remotely operated circuit breaker to the negative (-) terminal of the 24 Vdc power supply. Connect the red lead of the remotely operated circuit breaker to the positive (+) terminal of the 24 Vdc power supply. Connect the white lead of the remote control device. The remote control device provides connections between either positive or negative potential of the power supply and the white wire of the remotely operated circuit breaker, as appropriate.
- Applying the positive potential of the power supply to the white wire (contact closure between the red wire and white wire) will operate the remote mechanism of the circuit breaker to the OFF position. Applying the negative potential of the power supply to the white wire (contact closure between the black wire and the white wire) will operate the remote mechanism of the circuit breaker to the ON position. A control circuit utilizing a normally open (NO)/normally closed (NC) contact is illustrated below.

*NOTE: The remote mechanism will not move the circuit breaker handle. Also, the remote mechanism cannot turn power ON when the circuit breaker is tripped (VISI-TRIP® flag indicator showing) or when the circuit breaker handle is in the OFF position.*

**Installation of the trim and operational checks**

- Remove corresponding twist-out from panelboard trim and replace trim.
- Turn power to panelboard on.
- Turn remotely operated circuit breaker handle to the ON position.
- Turn power to the remotely operated circuit on and test this circuit, turning remotely operated circuit breaker off remotely, then on remotely. If power to remote controlled circuit breaker load does not switch off and on, turn off power to remotely operated circuit and panelboard and check wiring.

*NOTE: A power supply is available from Square D Company, Cat. No. QOPLPS (plug-on) or QOBPLPS (bolt-on).*

**Splice not normally required with LynTec supplied breakers with 60" leads.**

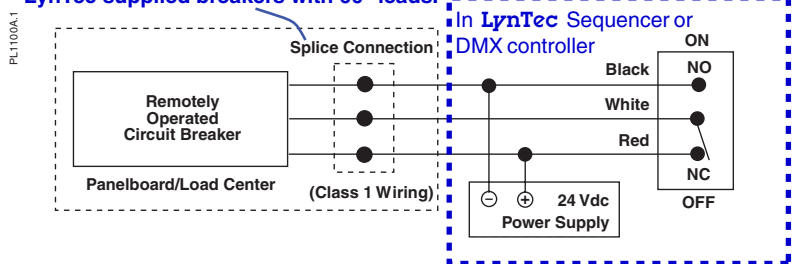

Electrical equipment should be installed, operated, serviced and maintained only by qualified personnel. No responsibility is assumed by Schneider Electric for any consequences arising out of the use of this material.

© 1991-2003 Schneider Electric All Rights Reserved

**A.C. Sequencing Systems**

**Wire requirements**

Switch set to sequencer: 4 conductors.  
 Between daisy chained sequencers:  
 9 conductors, 11 if Power Vouchers are used.  
 Up to 2500 ft. run: 24 ga.  
 2,500 to 3,750 ft. run: 22 ga.

To LynTec  
 PDS, MRTS, MSLC,  
 SLC, MSP or SP  
 series sequencer

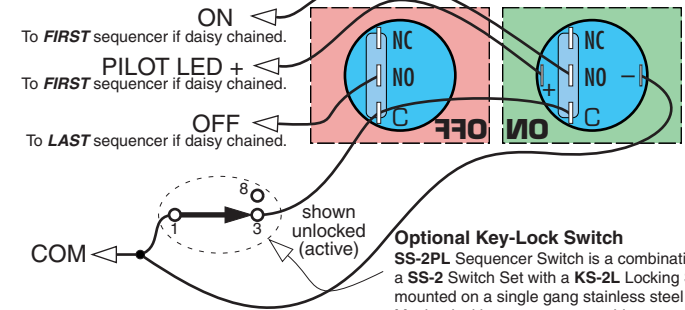

See reverse side for multiple switch set wiring.

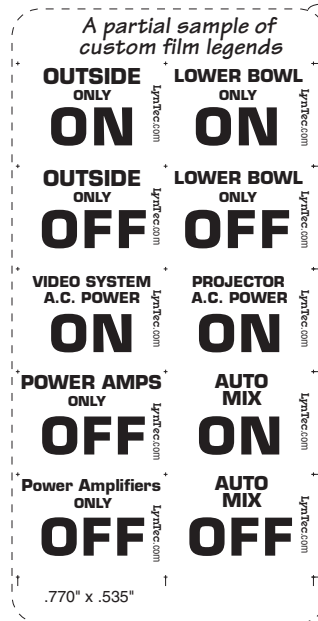
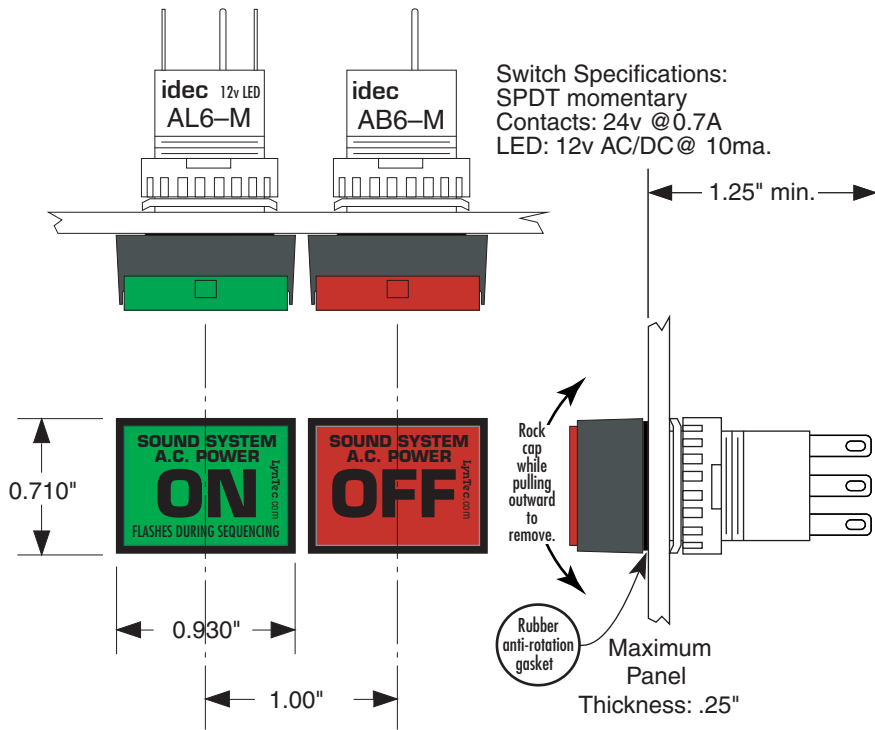

**Actual size drill templates**

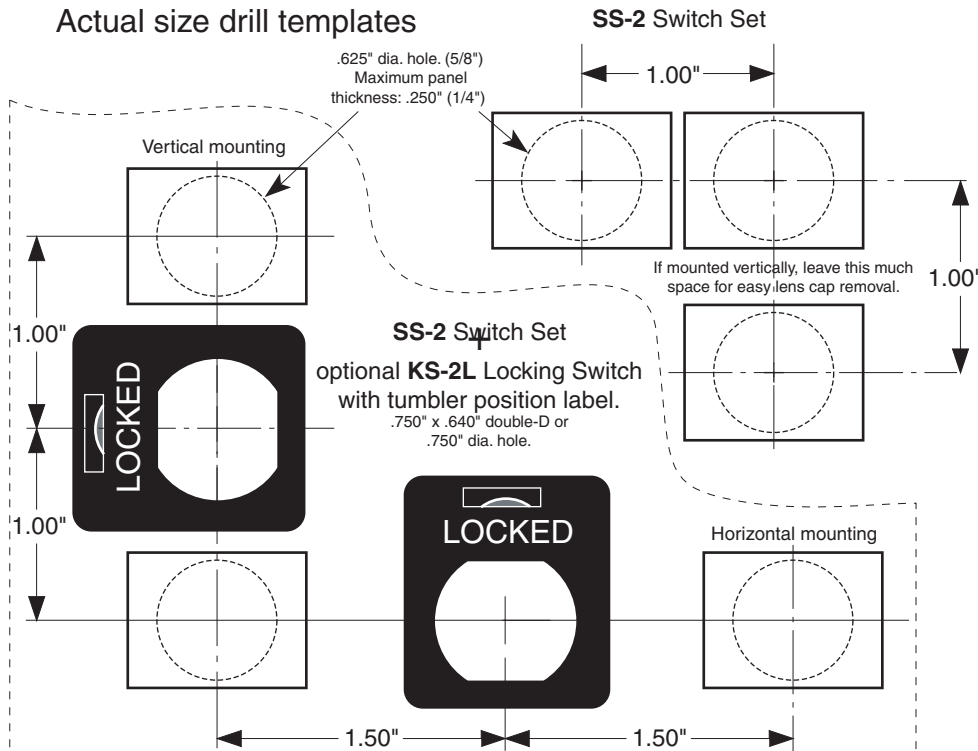

**LynTec**

**one**

**SS-2 Sequencer Switch Set**

Up to 5\* additional remote control locations may be added to the system with additional switch sets or with other momentary switches.



# Multiple Sequencer Hookup Diagram

For **LynTec MSLC** and **MSP MODULAR** and **PDS-8EK** Power Sequencing Products

Custom switch legends you can print on your laserprinter

Showing Low-Voltage Remote **ON/OFF** Control and Daisy-Chain Wiring

See [http://www.lyntec.com/139-0309\\_CSLF-1\\_Film.pdf](http://www.lyntec.com/139-0309_CSLF-1_Film.pdf)

One set of the **ON** and **OFF** switches shown below are supplied unmounted as a **SS-2** Switch Set with each LynTec sequencer cabinet. Mount in 5/8" dia. round holes in panels up to 1/4" thick.



**LynTec Model SS-2PL**  
Locking Switch Set.  
(Optional)

Switch layout for field constructed panel mounting.  
1/4" max. panel thickness.

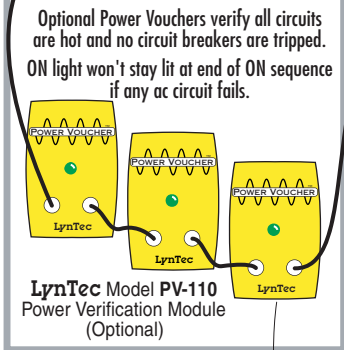
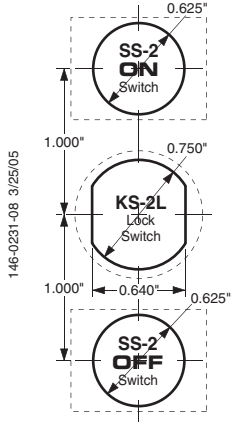

**LynTec Model PV-110**  
Power Verification Module  
(Optional)

★ Parallel connect additional SS-2 switch sets for multiple remote control locations.  
**4 conductors, 24 ga., 5,000 ft. loop max.**

Maximum number of switch sets:

All LynTec sequencers support 6 switch sets.

**LynTec**  
Lenexa, KS (Central time zone) U.S.A.  
Voice **800-724-4047** or 913-529-2233  
Fax **888-722-4157** or 913-529-4157  
[www.LynTec.com](http://www.LynTec.com)

For **single** sequencer board hookup connect OFF switch normally open to OFF.

PILOT LED (green)

Cage clamp terminal blocks. Press white levers back with small straight-blade screwdriver to insert stripped wires.

These expansion terminals on the top or middle boards are NOT used when the cascade connectors are used to daisy-chain boards within a cabinet.

**FIRST**  
Sequencer Board (Top)

**NOT in PDS-8EK**  
See daisy-chain connections below for wiring between PDS-8s or multiple cabinets.

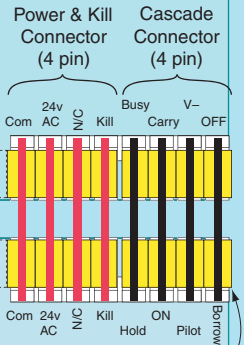

When sequencers are daisy-chained **avoid** using these test switches. Use the **first ON** test switch and the **last OFF** test switch to avoid confusing operation.

For multiple control points add SS-2's or SS-2PL's. Parallel connect lines.

To run each sequencer board as a separate system, remove the **right** Cascade Connector. Connect ON, Pilot, Com & OFF to switch set.

To isolate the **Hurry-Off** and **Kill** functions, unplug **left** Power & Kill Connector and move to the left one step, mis-mating to eliminate the board-to-board Kill connection.

**LAST**  
Sequencer Board (Bottom)

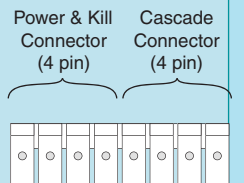

These expansion terminals on the **bottom** board are only used for daisy-chain connections when more than one cabinet is used.

### Kill — Fire alarm shutdown

External contact closure lights the red Kill LEDs and kills all sequenced power.

Contact opening restarts the ON sequence.

*See next page for enlarged daisy-chain hookup*  
**Low voltage control wire: 24 gauge minimum, 5,000 ft. loop max.**

A typical three panel, daisy-chained, system with two locking control locations.

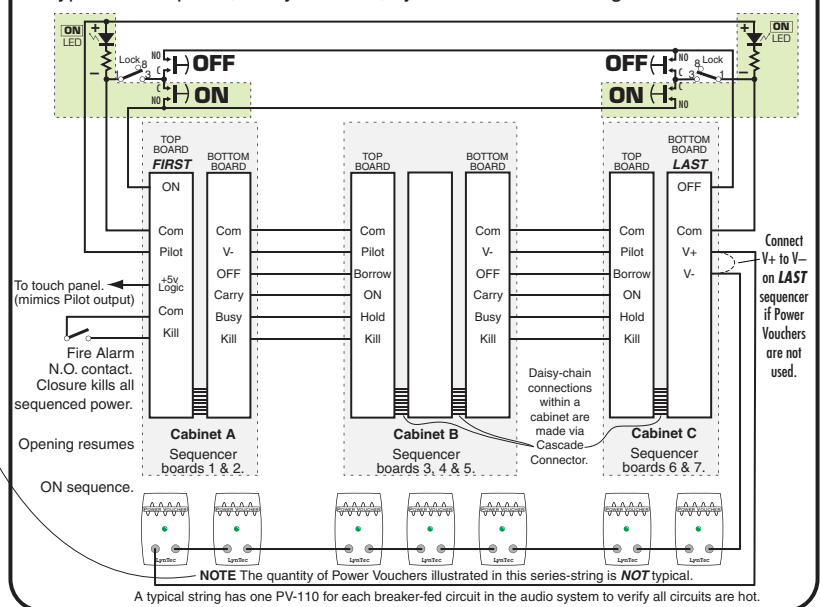

# A typical LynTec three panel, daisy-chained system with two locking control locations.

For Timing Diagram and Logic levels  
See [http://www.lyntec.com/139-0266\\_Seq\\_Timing.pdf](http://www.lyntec.com/139-0266_Seq_Timing.pdf)

## Wire Requirements for Remote Controls

- Basic system ON/OFF Control from one panel only ....4 conductors
- Basic + Kill Add Kill function .....6 conductors
- 2 conductors to Kill control location
- Remote control at both ends .....9 conductors
- Kill, Remote control both ends, full power verification .....11 conductors
- Low voltage control wire: 24 gauge minimum, 5,000 ft. loop max.

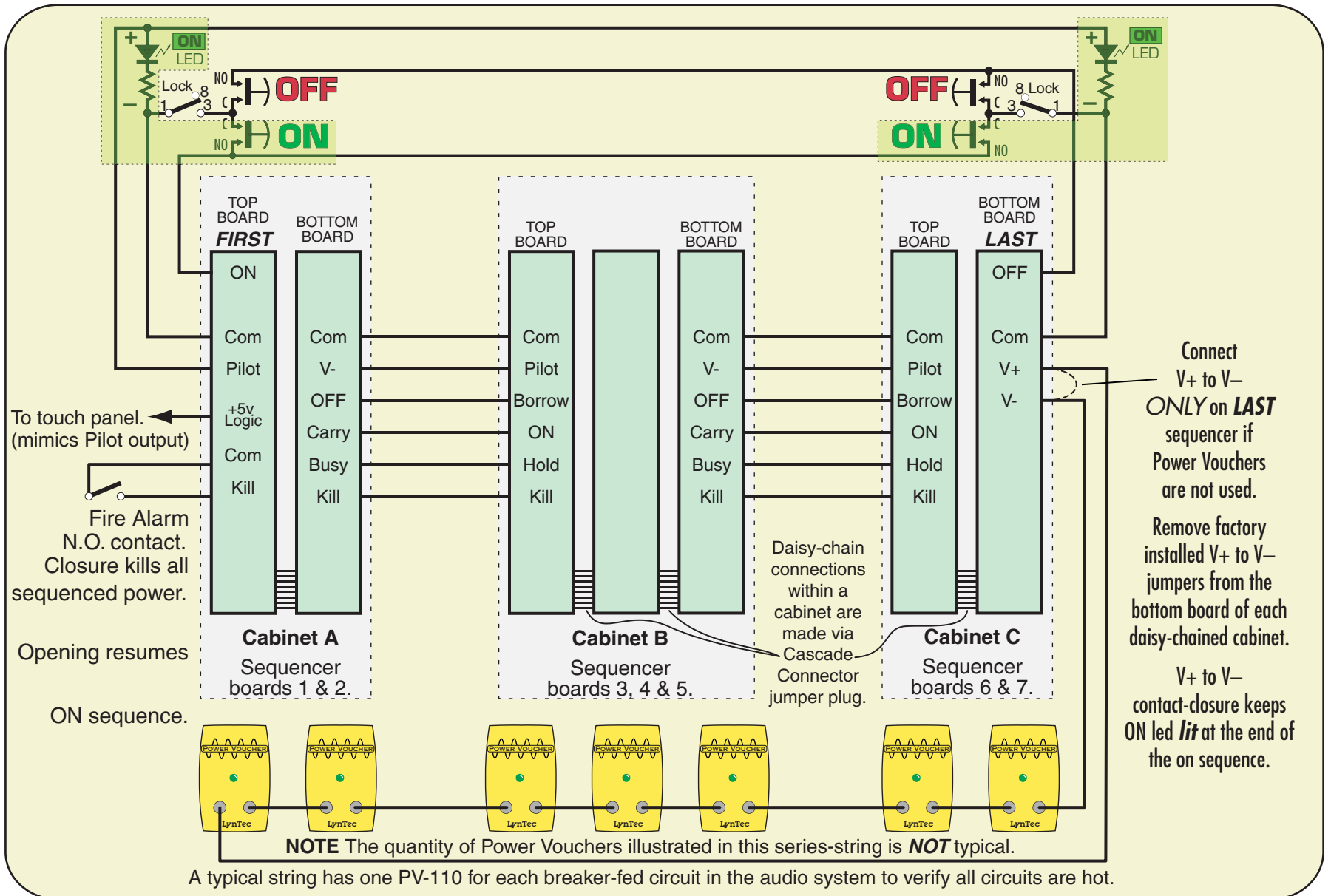

# Built-in Kill, Hurry-Off and ZipOff (PANIC) switch option for MSLC and MSP and PDS-8EK series AC SEQUENCING SYSTEMS

## What the functions do

### Kill — EMERGENCY SHUTDOWN

Provides an *IMMEDIATE* shut down method for the sound system at the command of a fire alarm, emergency announcement system, or ZipOff switch.

### Optional ZipOff switch, ZOS-5K

Provides a full AC Power shutdown within 250 milliseconds after the ZipOff button is pushed.

In case of a runaway oscillation or other unexpected signal which could damage the loudspeakers if sustained...

Lift the protective cover and press the ZipOff button... it latches down and lights red. The AC power sequencing system immediately zips off.

Press again to unlatch... the light goes out and the sequencer restarts to repower the system.

OR

Use the new Hurry-Off function at any OFF switch. 

### MULTI-BOARD SHUNT R

The Kill line is an 11 ma. current source from each MS-12 Modular Sequencer or PDS-8 EK board

A voltage sensor on the Kill line determines the Kill threshold.

The Kill line has an open circuit voltage of 28 volts which must be pulled down to less than 10.5 volts to generate a Kill function. Grounding the Kill line to Common will always kill the system instantly. This current source may also be used to light the Zip-Off switch's, red LED.

The red ZipOff LED only requires 10 ma. For systems where multiple-board system's Kill lines are paralleled, a 9 v. voltage regulator chip is installed in the ZOS-5K which will automatically shunt the excess source current of up to 5 boards. For more than 5 boards an additional resistor must be used in parallel with the ZipOff switch LED. To prevent damage due to overheating the voltage regulator chip, the resistor should be installed as shown with **full length leads** to get the heat source away from the switch.

Total Number of boards	Shunt Resistor required	
1-5	none	
6	820Ω, 1/4w	16
7	430Ω, 1/4w	17
8	270Ω, 1/2w	18
9	200Ω, 1/2w	19
10	150Ω, 1/2w	20
11	150Ω, 1w	21
12	120Ω, 1w	22
13	100Ω, 1w	23
14	92Ω, 1w	24
15	82Ω, 1w	25
		75Ω, 2w
		68Ω, 2w
		62Ω, 2w
		56Ω, 2w
		56Ω, 2w
		51Ω, 2w
		47Ω, 2w
		47Ω, 2w
		43Ω, 2w
		39Ω, 2w

## What to specify or order

For ZipOff switch order ZOS-5K. (services up to 5 Kill equipped boards)

Includes switch with ZipOff film legend and flip up security cover.

Switch mounts in 5/8" round hole in panels up to 3/16" thick.

ZOS-5K Contractor C.O.D. price: \$40.

Delivery: Stock.

### Hurry-Off

The MS-12 Modular & PDS-8EK Sequencing boards have a new Hurry-Off function. If you **hold down** any OFF switch for two seconds, a "Kill without restore" function is triggered. The system shuts down within 250 milliseconds and doesn't restart until you give it a new ON command. Kinda like a DSP undo command.

### How they work

All LynTec sequencing systems have the ZipOff load shedding feature. The older SLC, SP and PDS-8's implemented it by interrupting 24v ac power.

The newer Modular sequencers, the MSLC and MSP series and the PDS-8EK, load shed when power fails, but also have a Kill function that is triggered by grounding the Kill line.

The red Kill LED, adjacent to the Kill terminal on the board, lights and Zip-Off is immediate. The kill line is a low current line. Long control wiring may be used without concern for loop resistances up to 32Ω. (22 gauge, up to a 1,000 ft. run [2,000 ft. loop] or a 680 ft. run of 24 ga).

The ON/OFF *latching* pilot relay remembers that the sequencer was ON. When the Kill line is opened, the ON sequence repeats, bringing the AC power back on.

For the Modular series control boards the ZipOff switch connects the Kill line to common, through the Zip-Off switch's LED, initiating the Kill function.

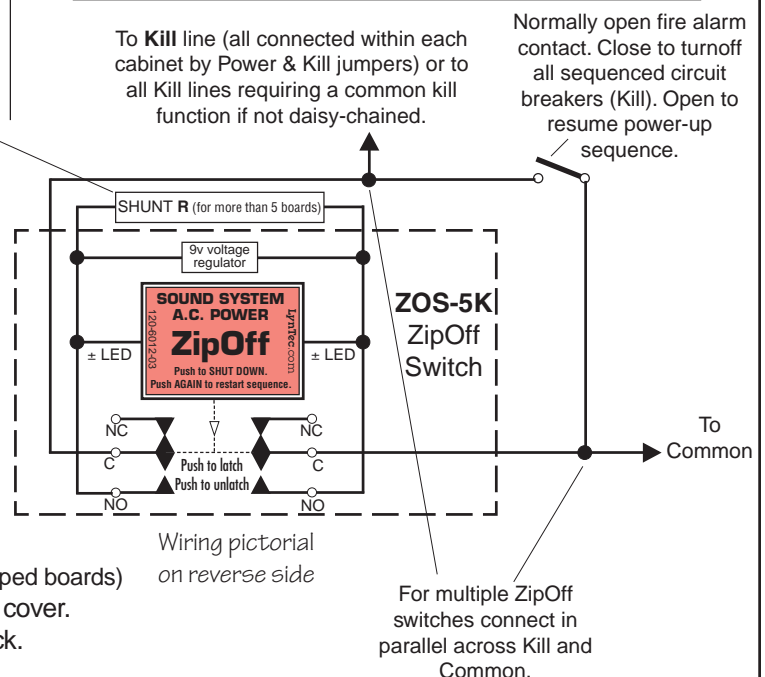

www.LynTec.com

8401 Melrose Drive • Lenexa, KS 66214 • Voice 800-724-4047 or 913-529-2233 • Fax 888-722-4157 or 913-529-4157

for **Modular A.C. Sequencing Systems**, models **MSLC, MSP & PDS-8EK.**

## ON, OFF and ZipOff switch mounting & wiring

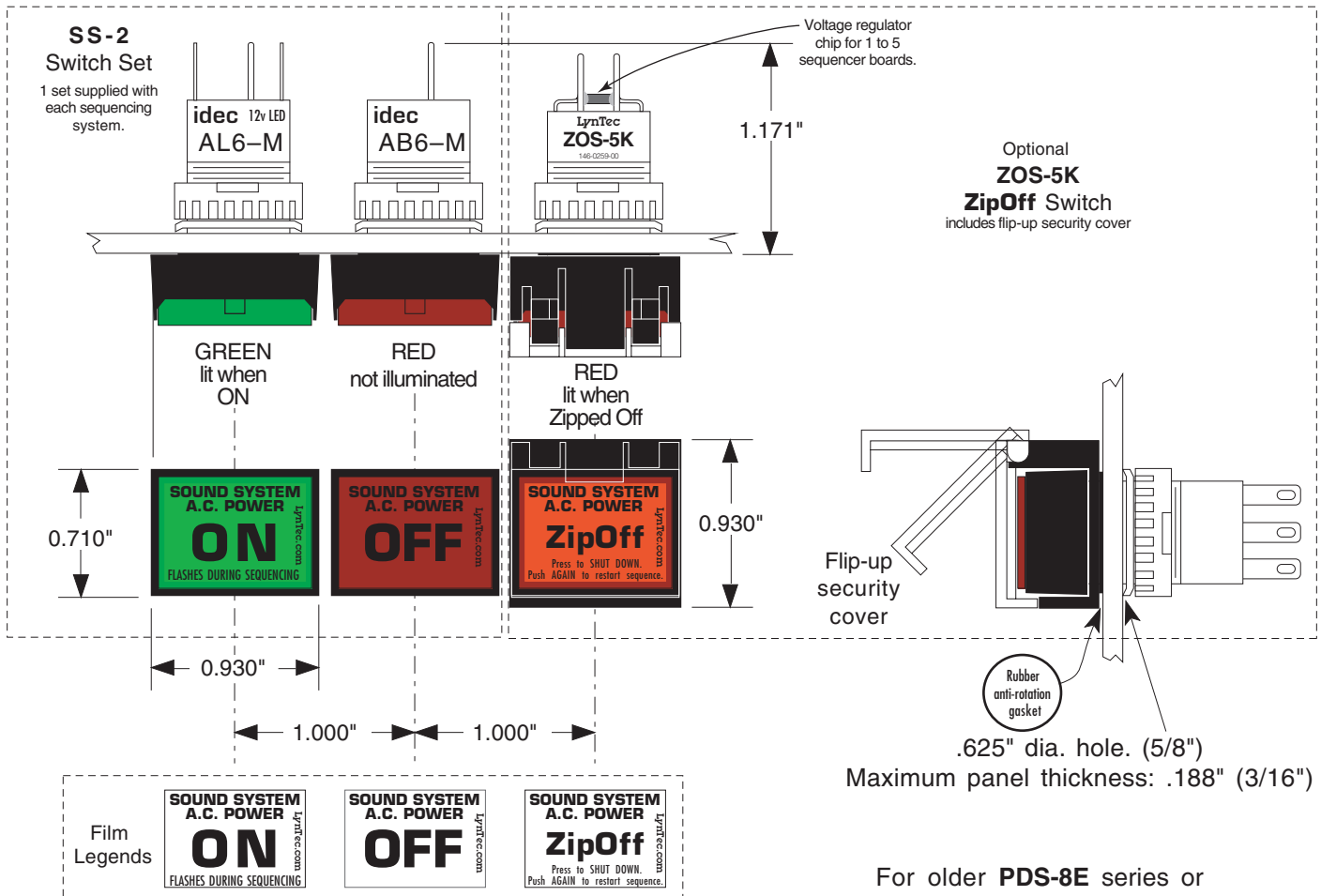

### Wiring pictorial - Rear view

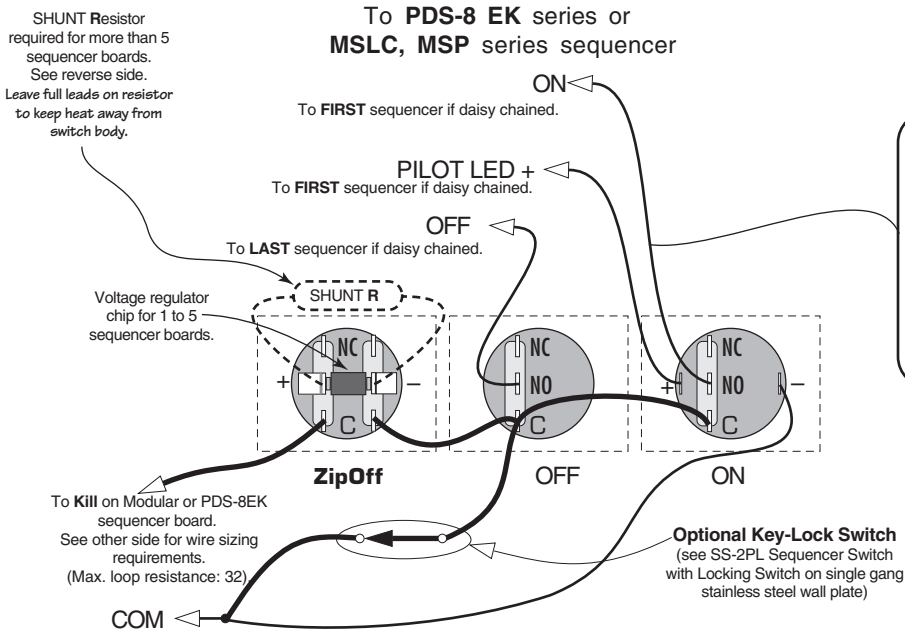

#### Wire requirements

Switch set to sequencer: 4 conductors.  
Between daisy chained Modular sequencers: 9 conductors, 11 if Power Vouchers are used.  
Up to 5,000 ft. run: 22 ga.,  
5,000 to 7500 ft. run: 20 ga.,  
7,500 to 10,000 ft. run: 18 ga.  
See other side for **ZipOff** wire sizing.